



# BioPath

---

## Visualization of Biochemical Pathways

Franz J. Brandenburg,  
Michael Forster, Andreas Pick,  
Marcus Raitner, Falk Schreiber

# BioPath Project

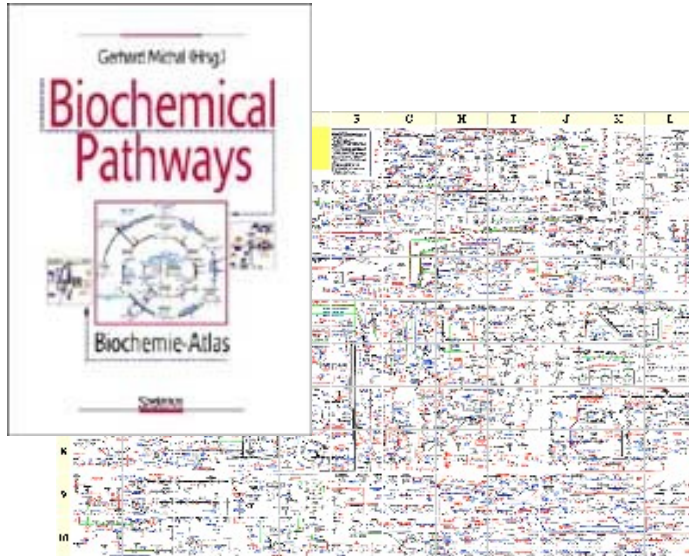

Electronic version  
**BioPath**

Project partners: University of Erlangen  
University of Mannheim  
University of Passau  
Spektrum Verlag Heidelberg



# Overview

---

- Visualization of Pathways
  - Static vs. dynamic visualization
  - Requirements
  - Solutions: Modeling & Algorithms
  - Results
- BioPath Prototype
  - System architecture
  - Screenshots
- Perspectives



# State of the Art

---

- Static visualization
- Manually produced drawings
  - Produced once
  - Used many times
  - Not changeable
- Used in
  - Biochemistry books
  - Boehringer Poster “Biochemical Pathways”
  - Electronic systems (KEGG, ExPASy, PUMA)

# Static Visualization Examples

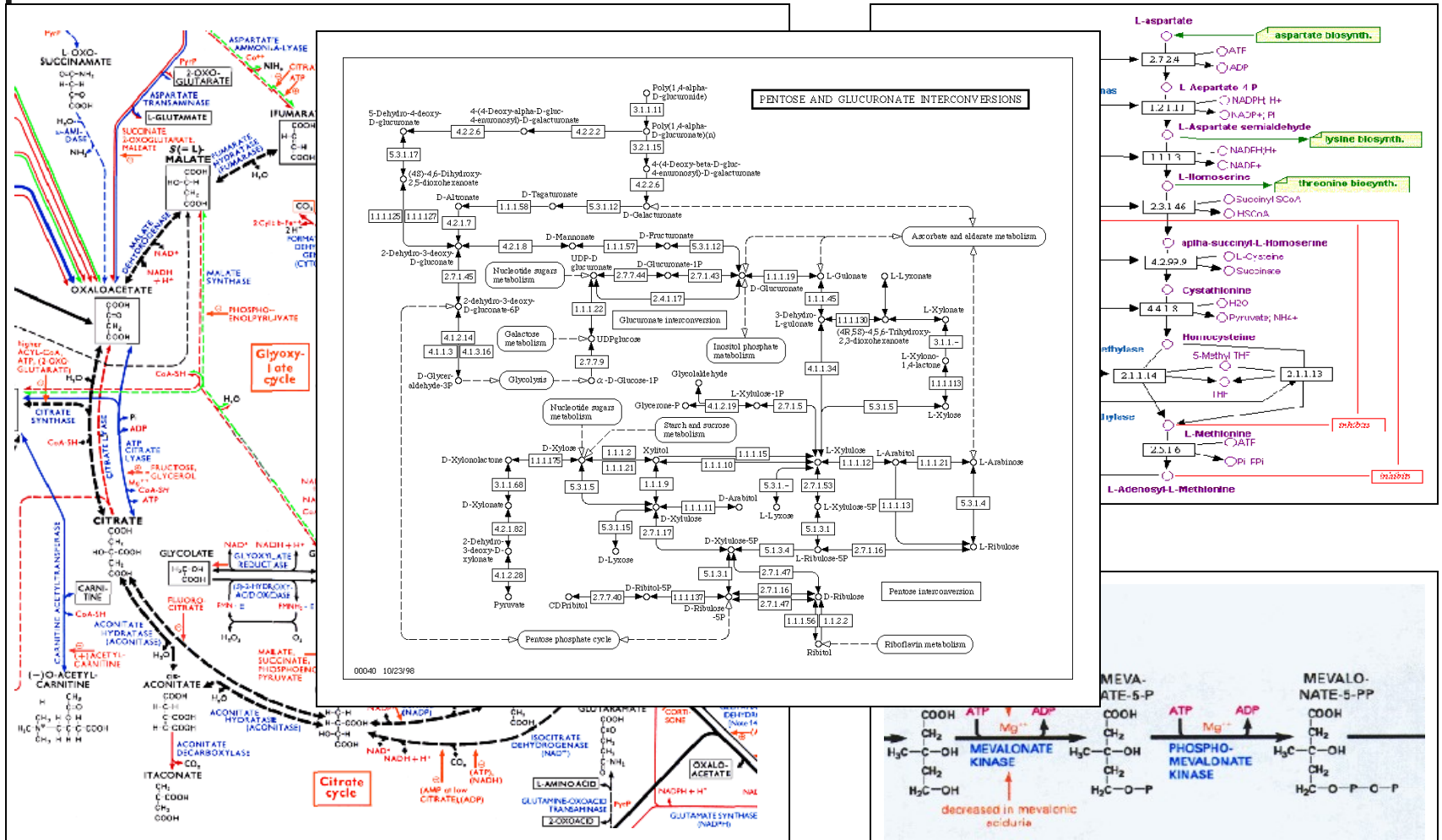

# Static Visualization Problems

- Very complex
  - Information overflow
  - Hard to find information (even with an index)
  - Not suited for answering specific questions
  - Only one view on the data

- Expensive

- Creation of Boehringer Poster
- Updates are difficult

Find pathway  
from **isovaleryl-CoA**  
to **acetyl-CoA**  
took > 1 year

→ **Dynamic visualization**



# Wishes

---

- Interactive Navigation
- Arbitrary views on the data
  - Part of the network
  - Part of the available information
  - Different levels of detail

# Pathway Hierarchy

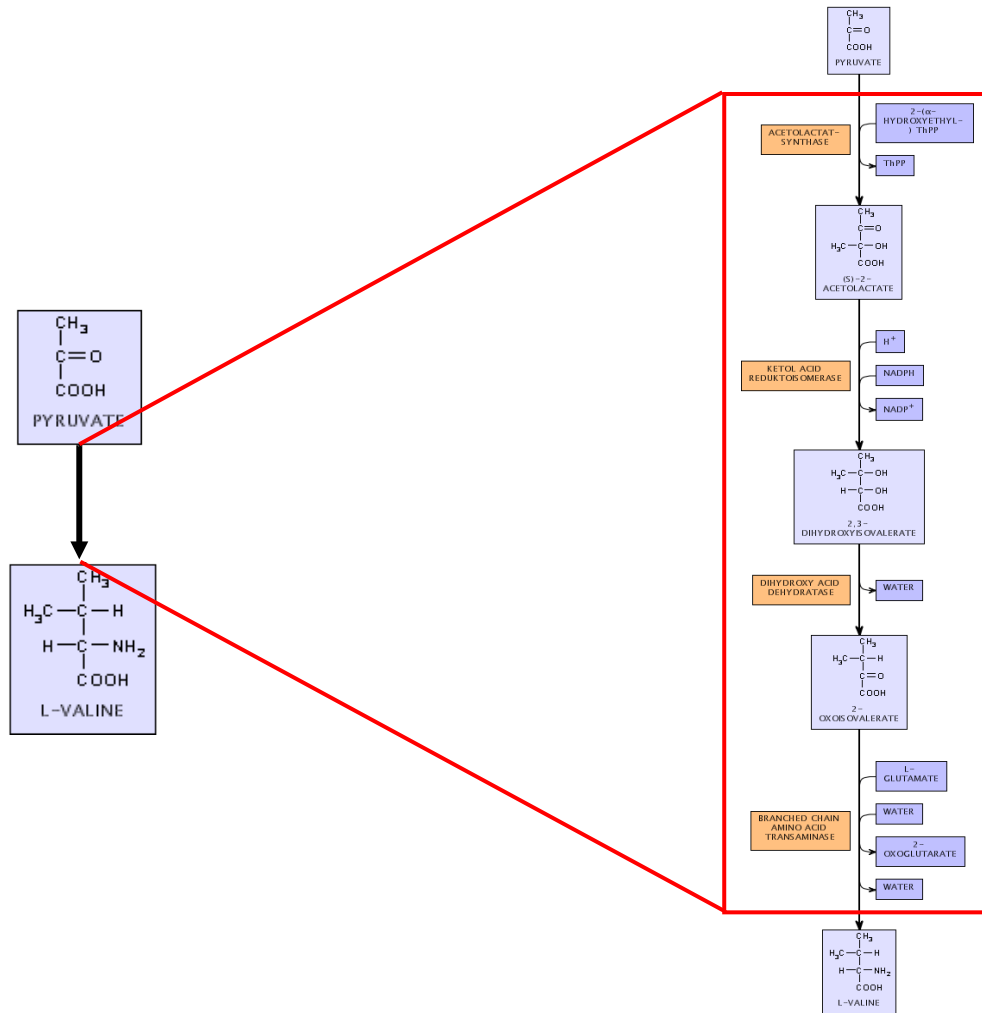





# Pathway Hierarchy

---

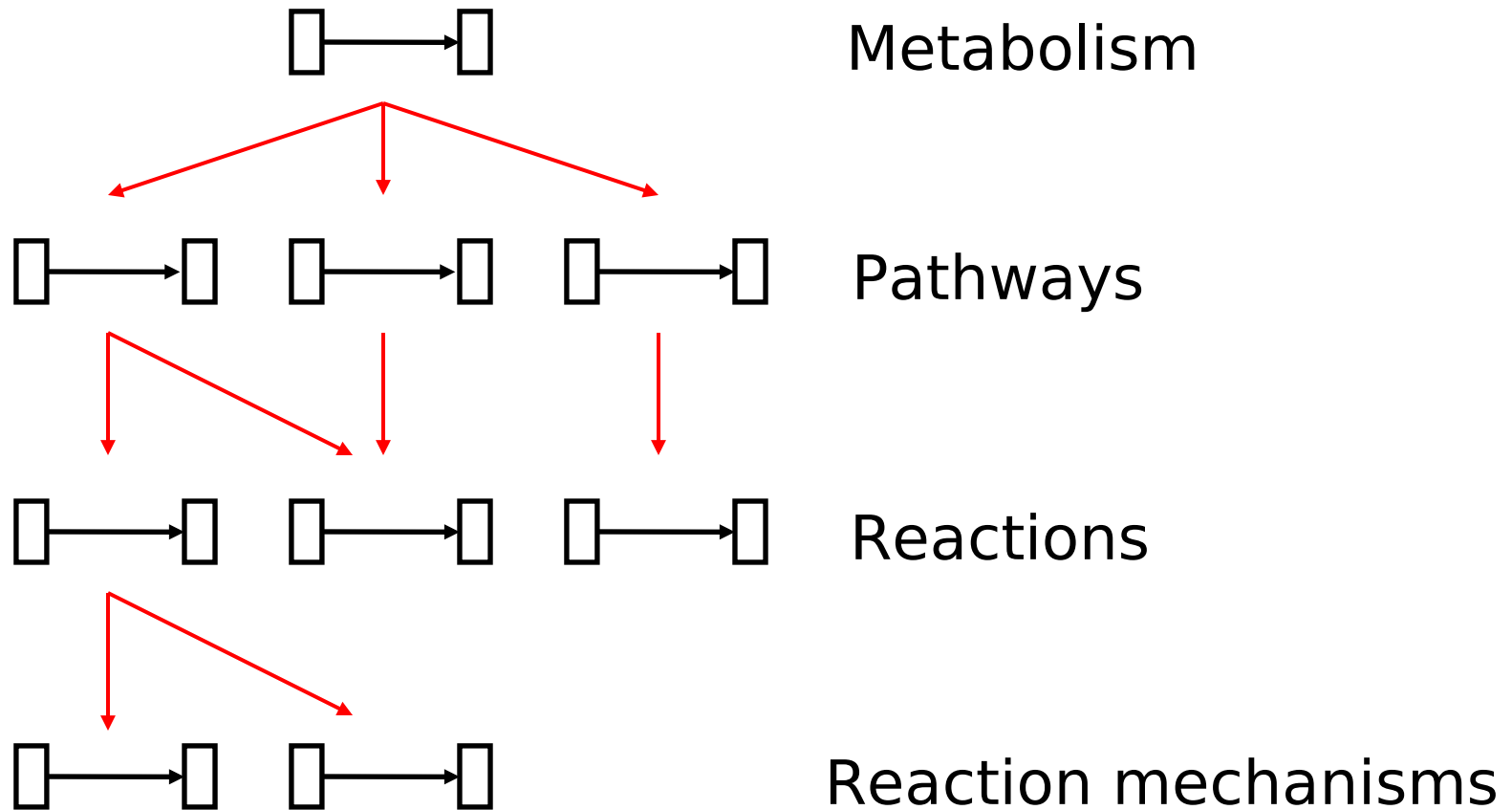

# Visualization Requirements

- Substances, co-substances, enzymes
  - Text and/or images
- Reactions
  - Substances: start/end of reaction arrow
  - Enzymes: along reaction arrow
  - Co-substances: along reaction arrow, according to chemical order
- Reaction networks
  - Distinct Direction
  - Predefined layout of special pathway structures

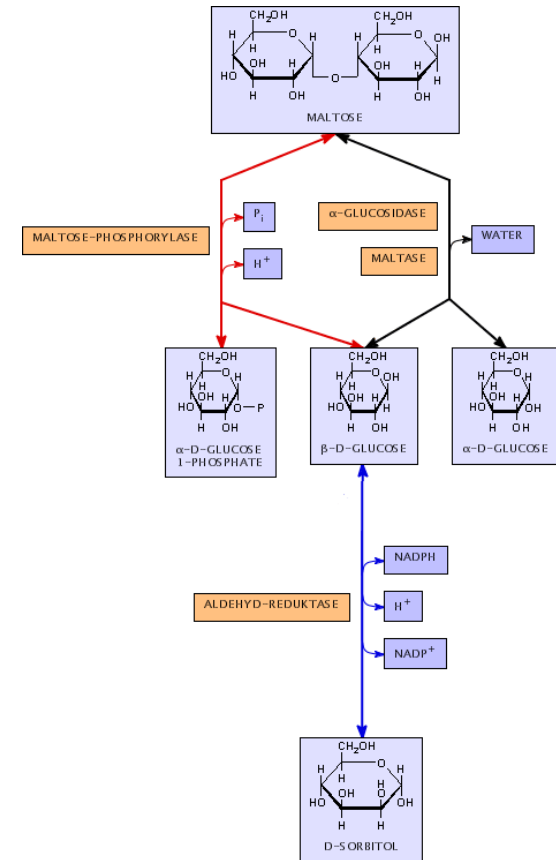

# Special Pathway Structures

- Closed Cycles
  - Sequence of related reactions
  - Product is **equal** to educt

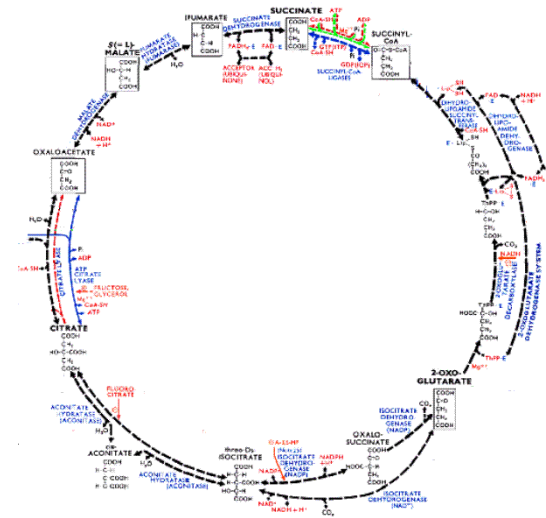

- Open Cycles
  - Sequence of related reactions
  - Product is **similar** to educt

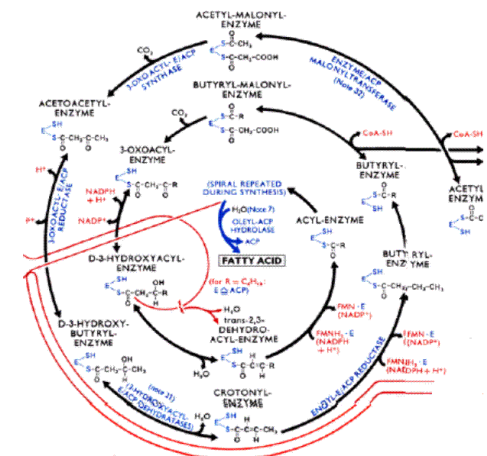

# Drawing Conventions

- Substances, co-substances, enzymes
  - Text and/or images
- Reactions
  - Substances: start/end of reaction arrow
  - Enzymes: along reaction arrow
  - Co-substances: along reaction arrow, according to chemical order
- Reaction networks
  - Distinct Direction
  - Predefined structures of special pathway structures (e. g. citrate cycle)
- Sequences of networks
  - Context-preserving layouts

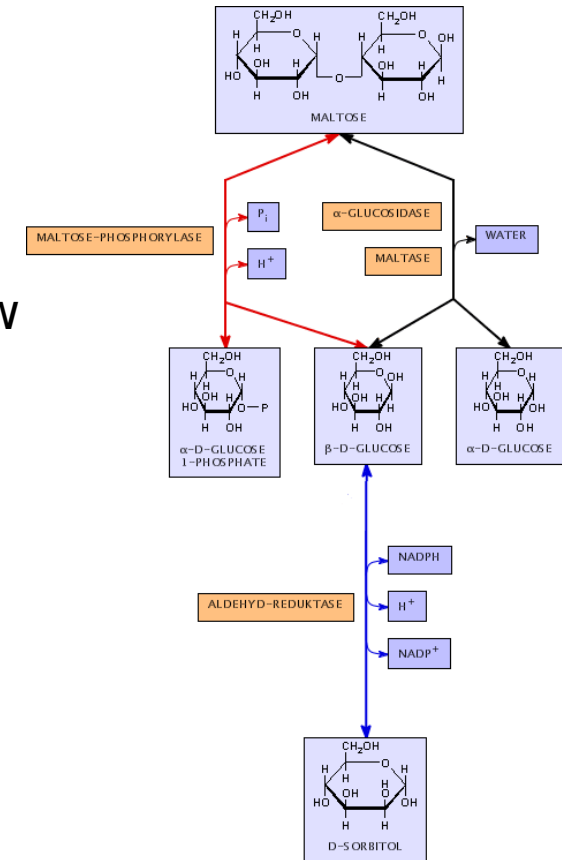

# Context Preservation

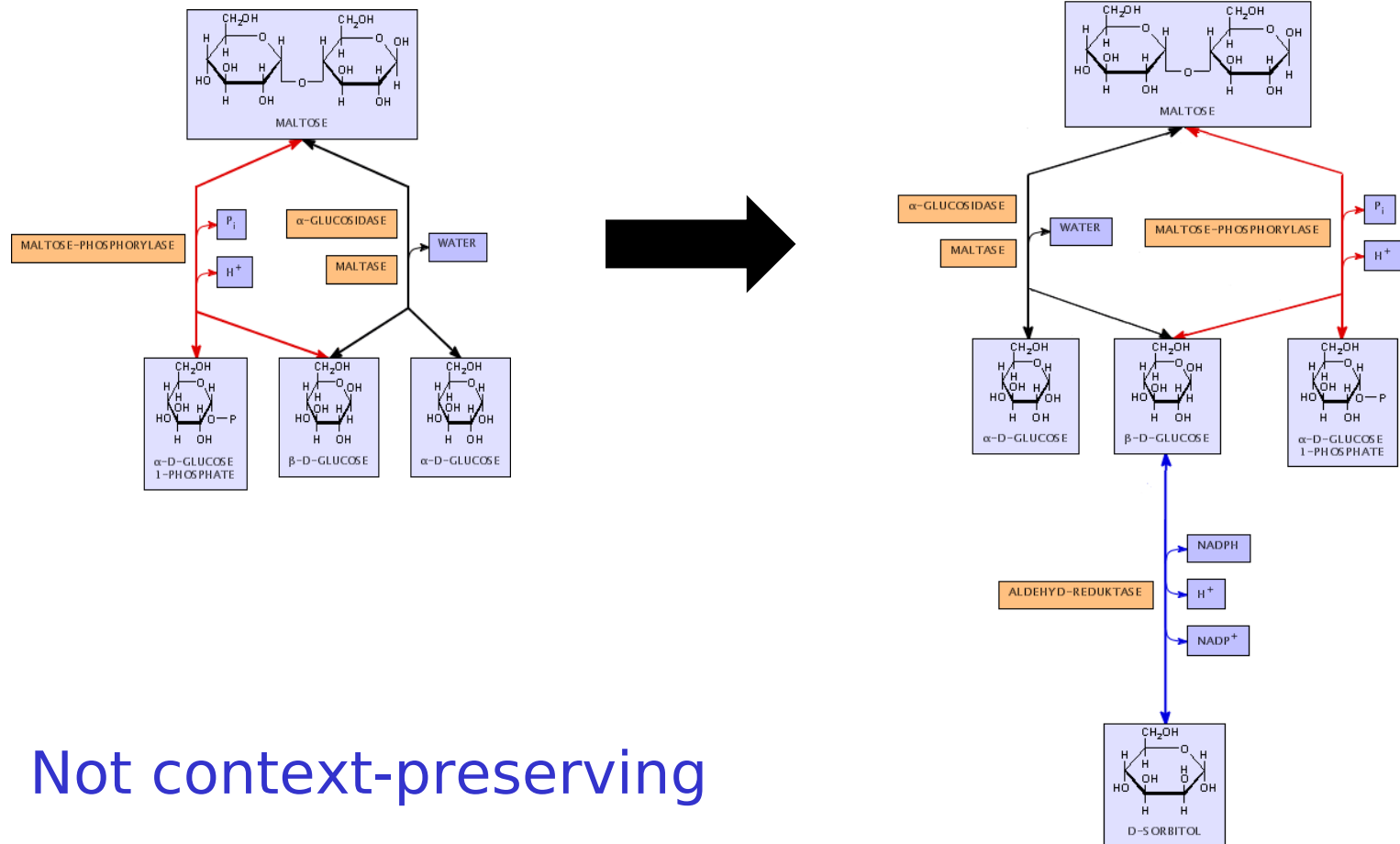

Not context-preserving

# Context Preservation

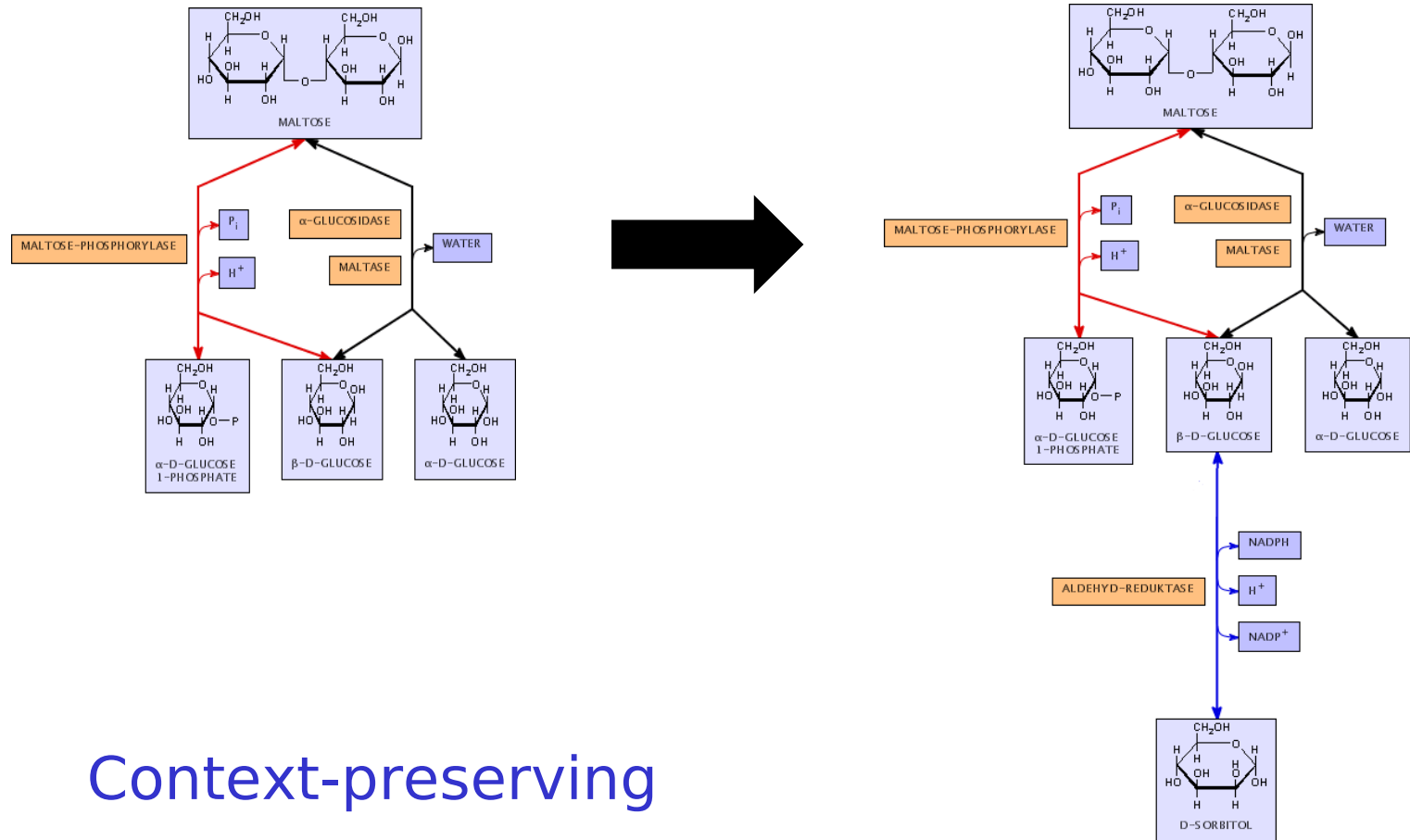

Context-preserving

# Modeling of Reactions

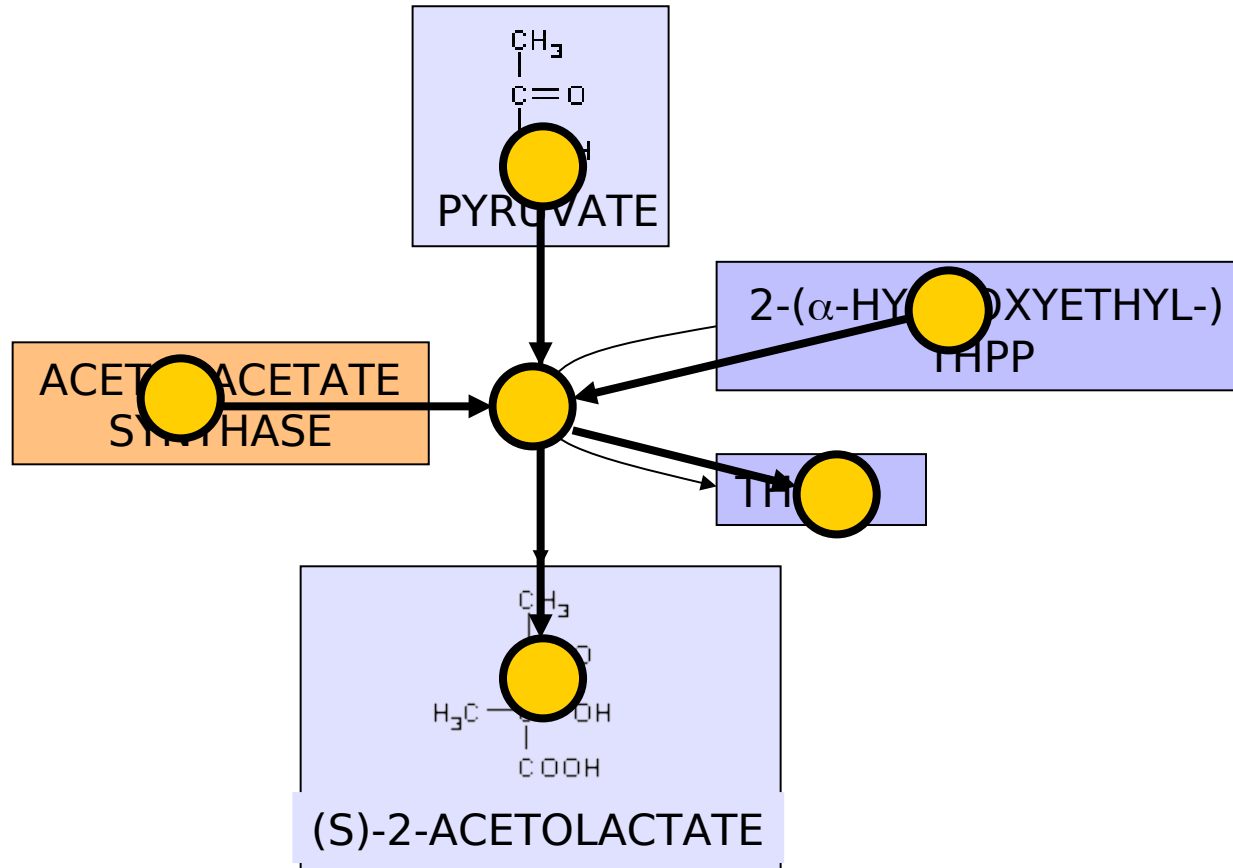



# Graph Drawing

---

- Given: Graph
- Wanted: “Nice” Drawing
  - Node positions
  - Edge routing
- Several standard algorithms
  - Force directed (Spring Embedder)
  - Hierarchical (Sugiyama)
  - Specialized Algorithms for
    - Trees
    - Planar Graphs
    - Other special classes of graphs



# Standard Algorithms

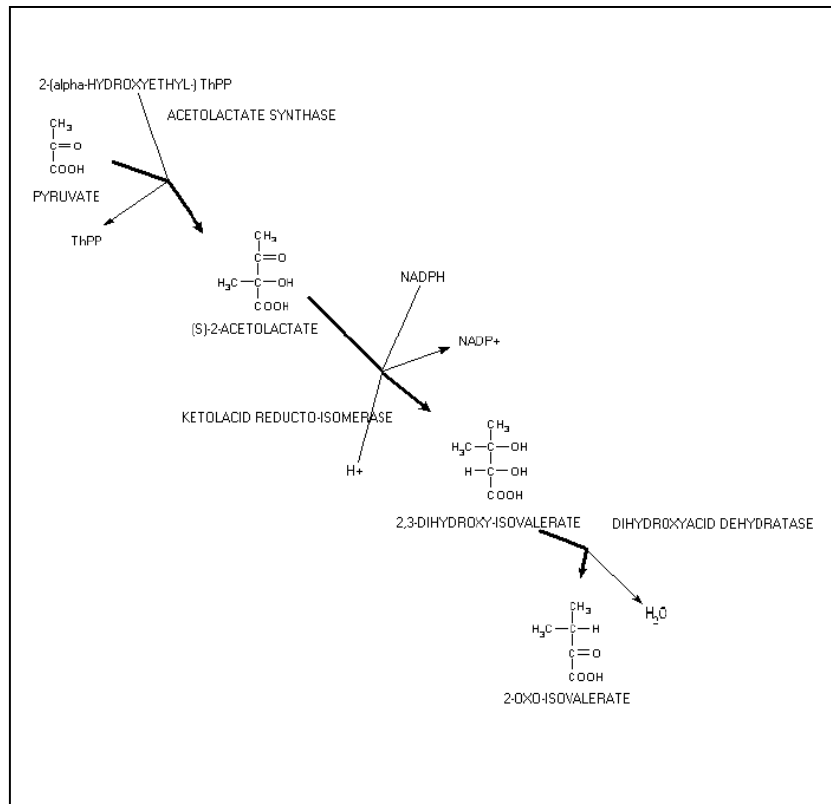

Spring Embedder

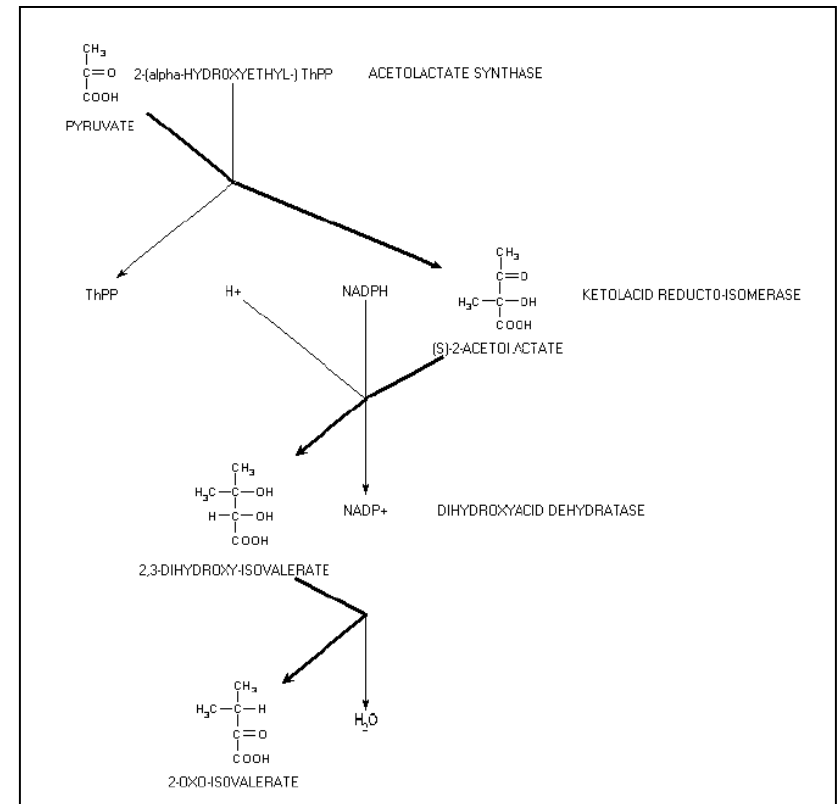

Sugiyama



# New Algorithm

---

- Too technical for presentation here
  - Several problems proven to be NP-hard
  - Efficient heuristics
- Extension of Sugiyama algorithm
  - Arbitrary node sizes
  - Layout constraints
    - Special pathway structures
    - Context preservation

# Results

- Reactions
- Reaction networks
  - closed cycles
  - open cycles

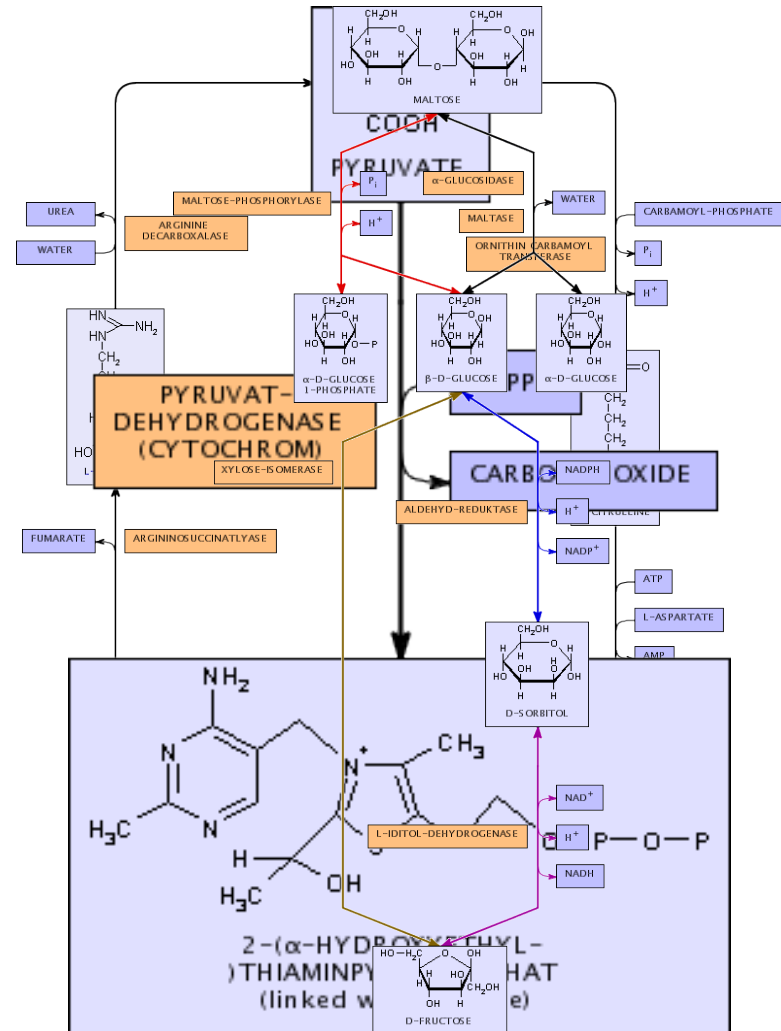

# Results - Open Cycles

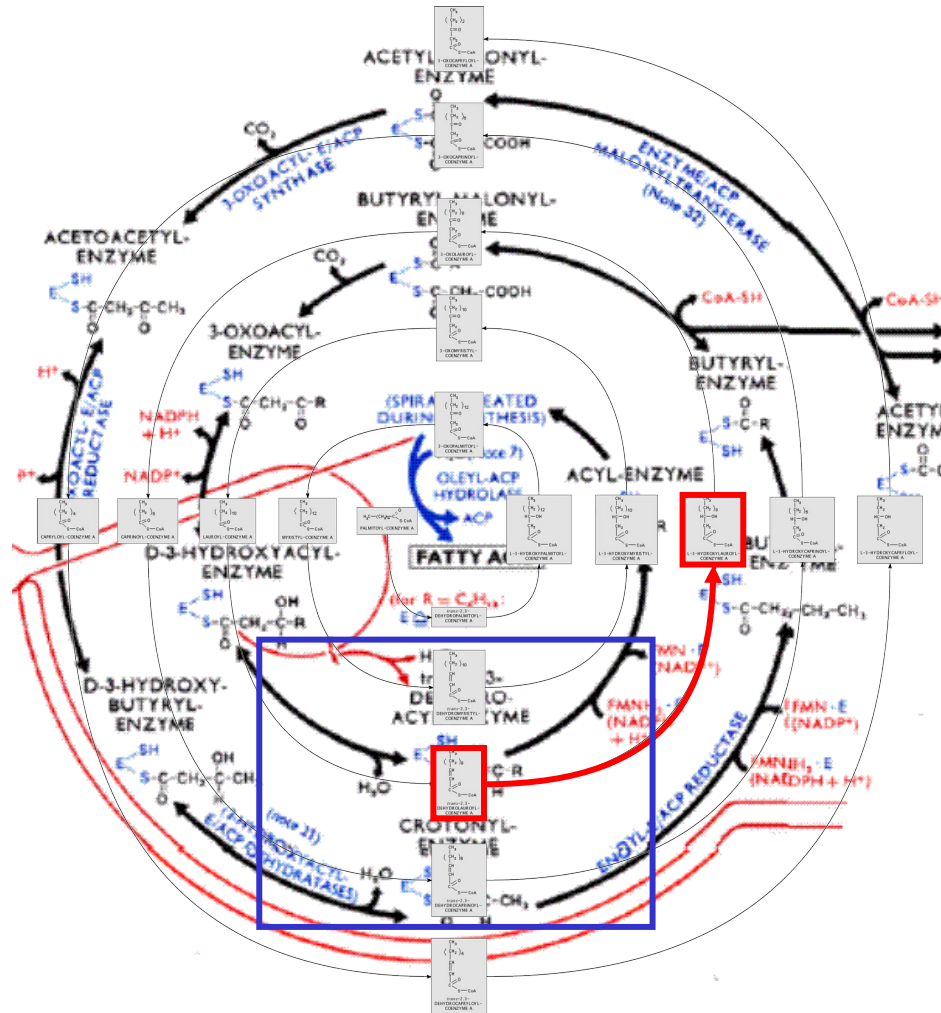

# Results - Open Cycles

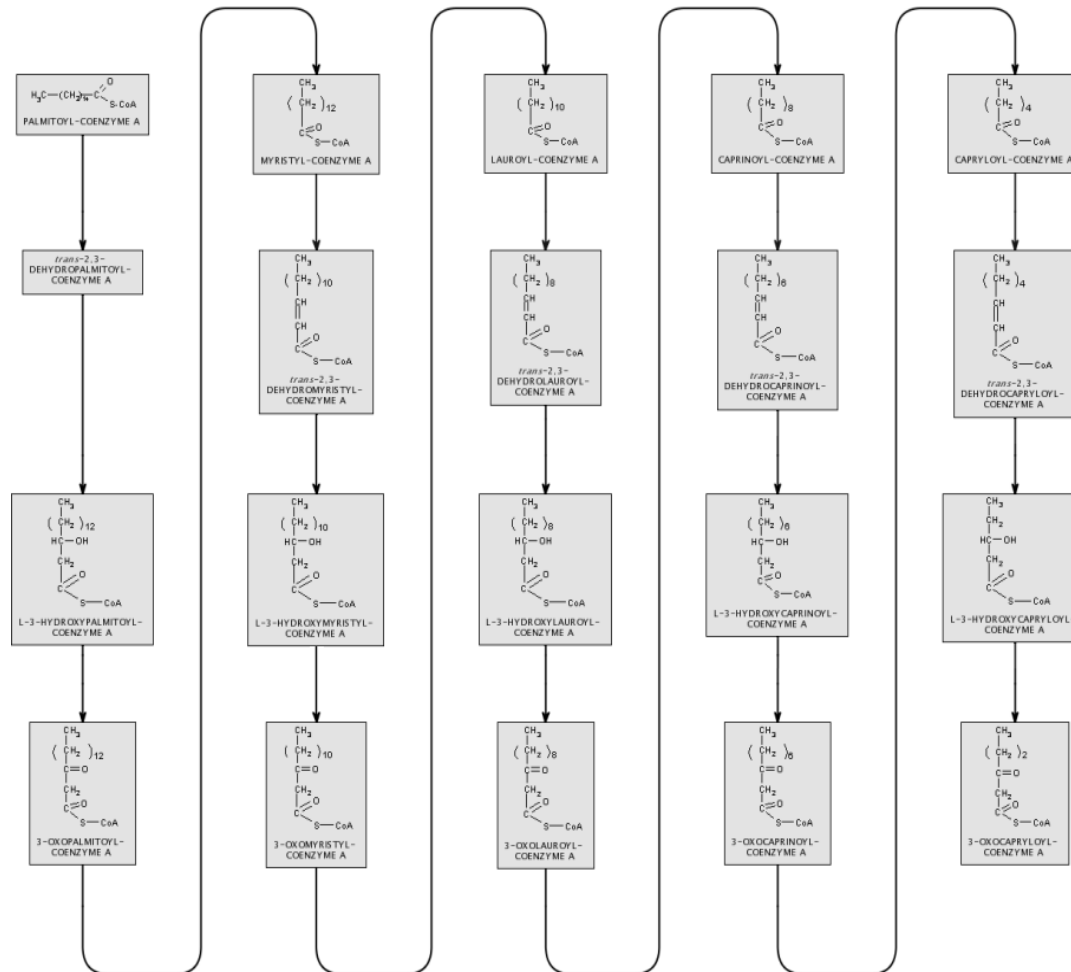

# Results - Open Cycles

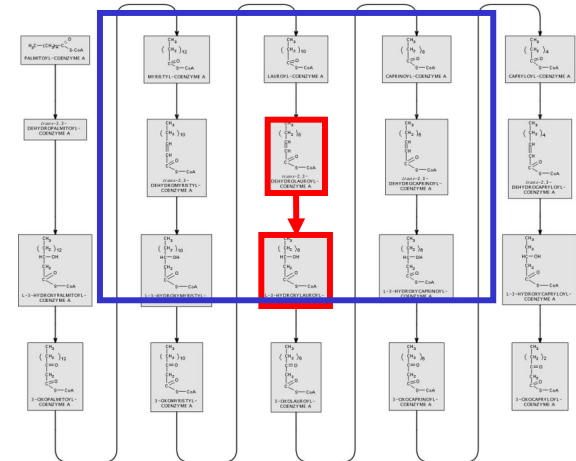
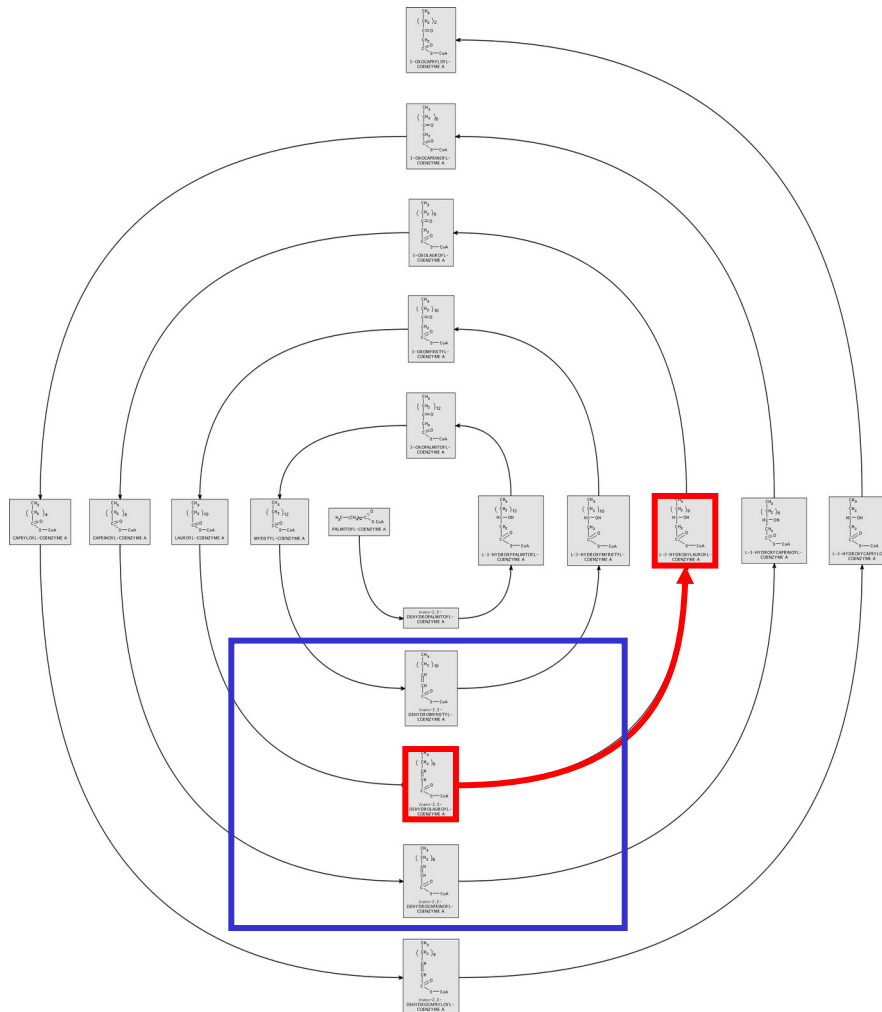

# Results

- Reactions
- Reaction networks
  - closed cycles
  - open cycles

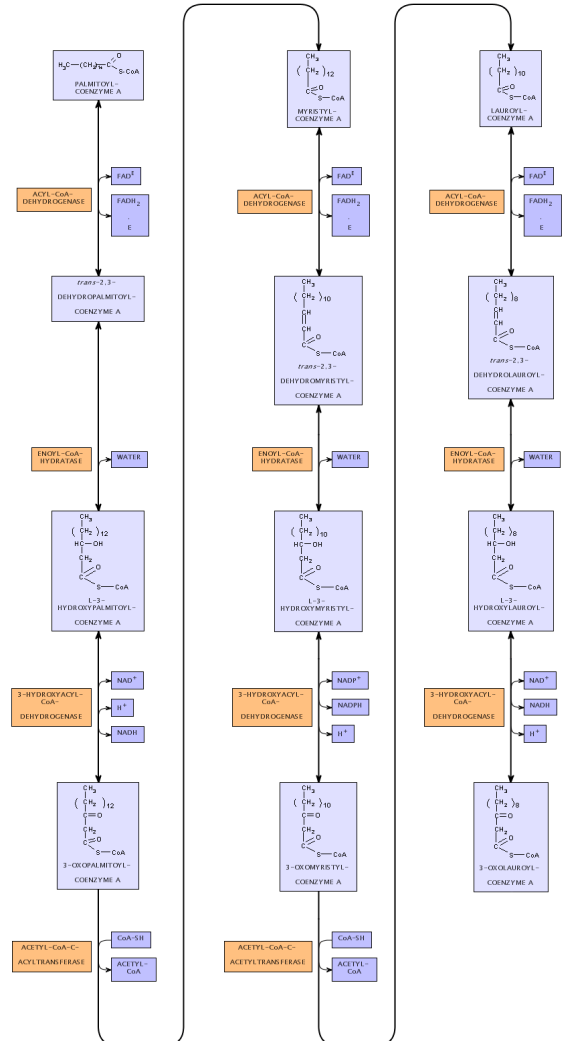

# Results

- Reactions
- Reaction networks
  - closed cycles
  - open cycles
- Different views

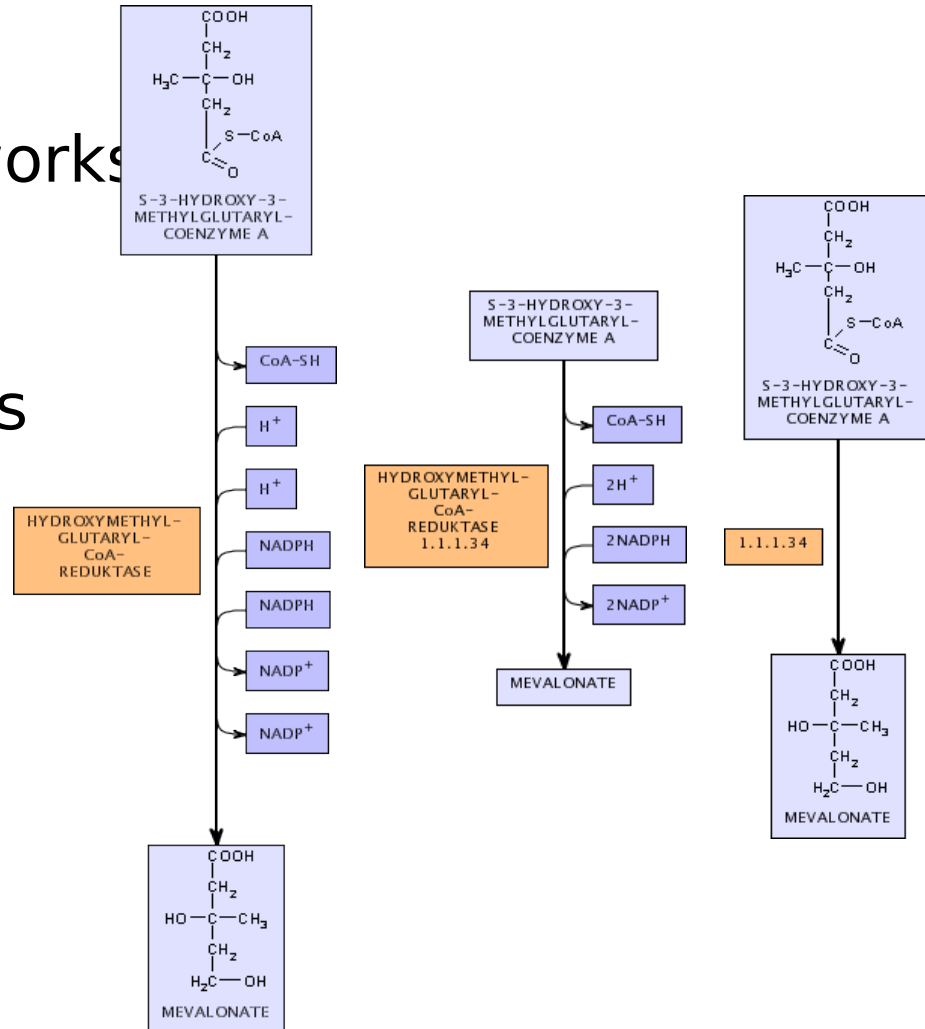



# Results

- Reactions
- Reaction networks
  - closed cycles
  - open cycles
- Different views
- Different levels of detail

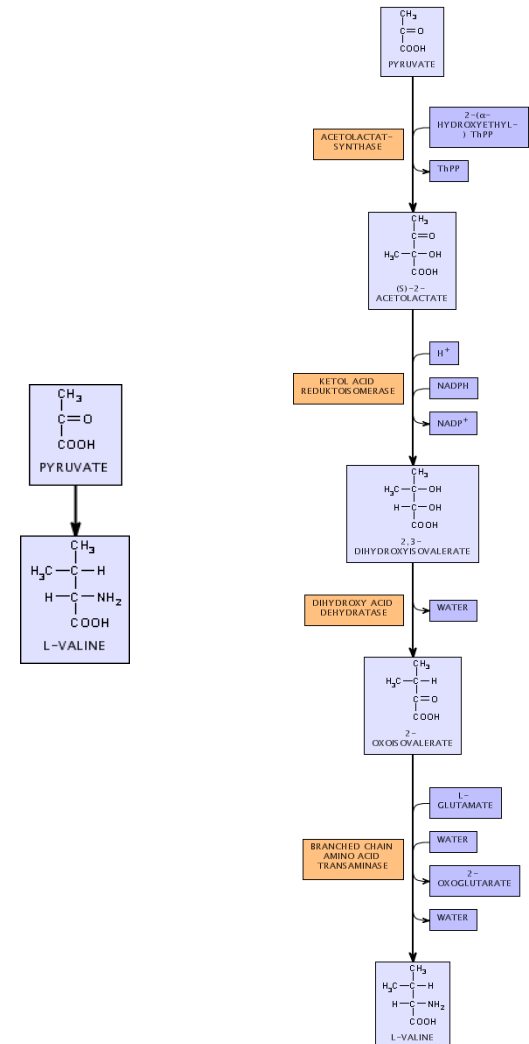

# Results

- Reactions
- Reaction networks
  - closed cycles
  - open cycles
- Different views
- Different levels of detail
- Preserving the context

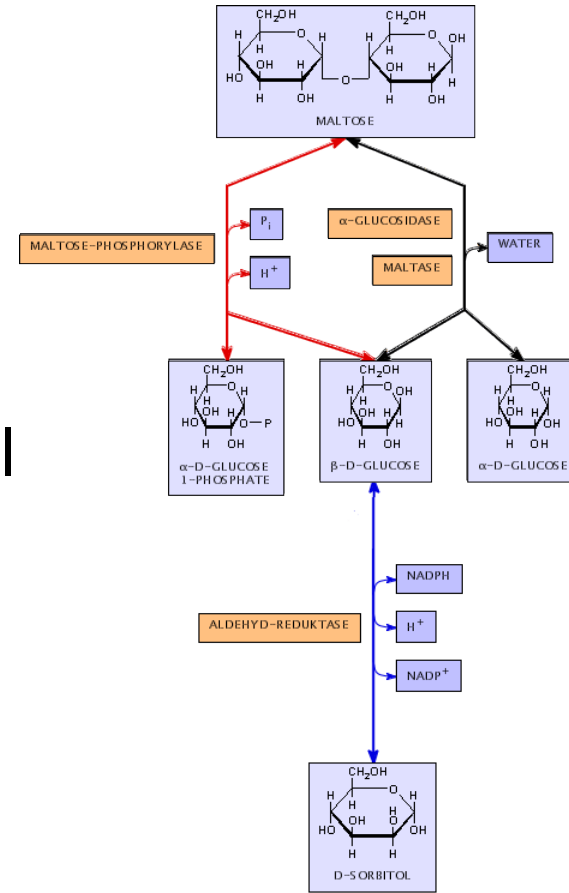

# Results

- Reactions
- Reaction networks
  - closed cycles
  - open cycles
- Different views
- Different levels of detail
- Preserving the context
- Extensible
  - new information

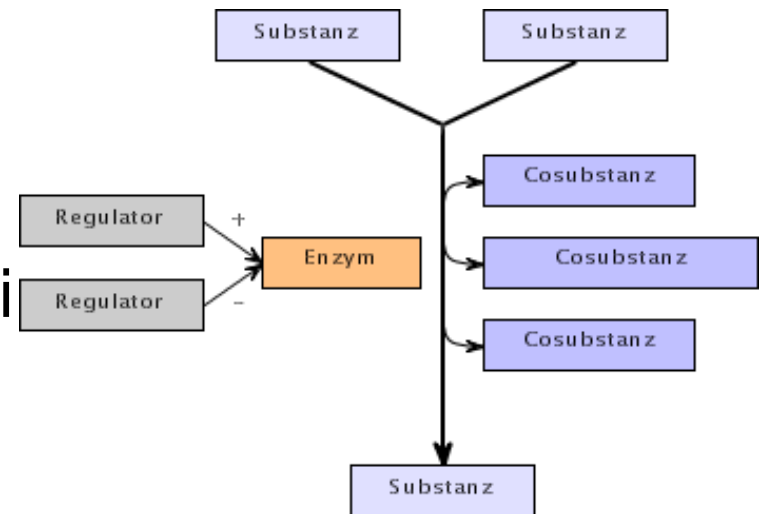

# Results

- Reactions
- Reaction networks
  - closed cycles
  - open cycles
- Different views
- Different levels of detail
- Preserving the context
- Extensible
  - new information
  - new applications

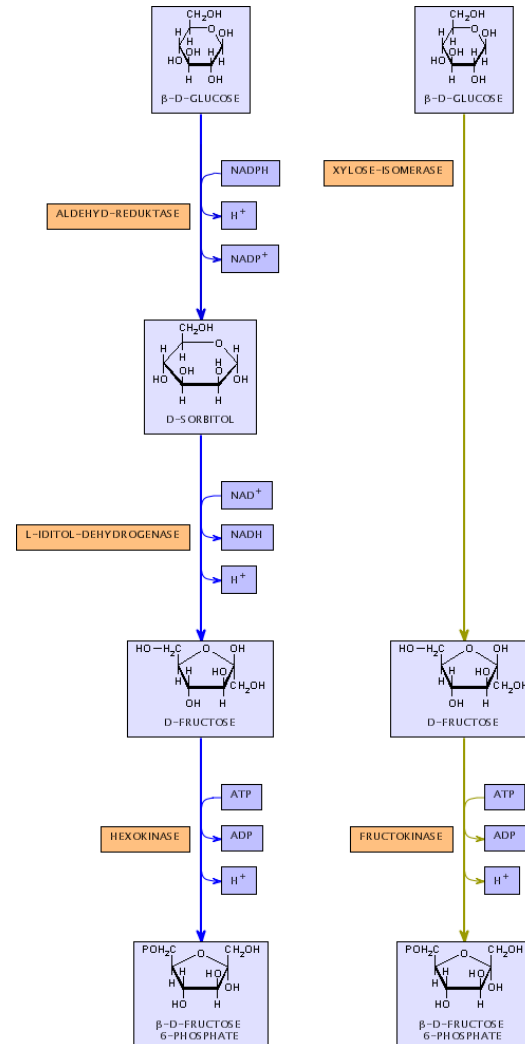

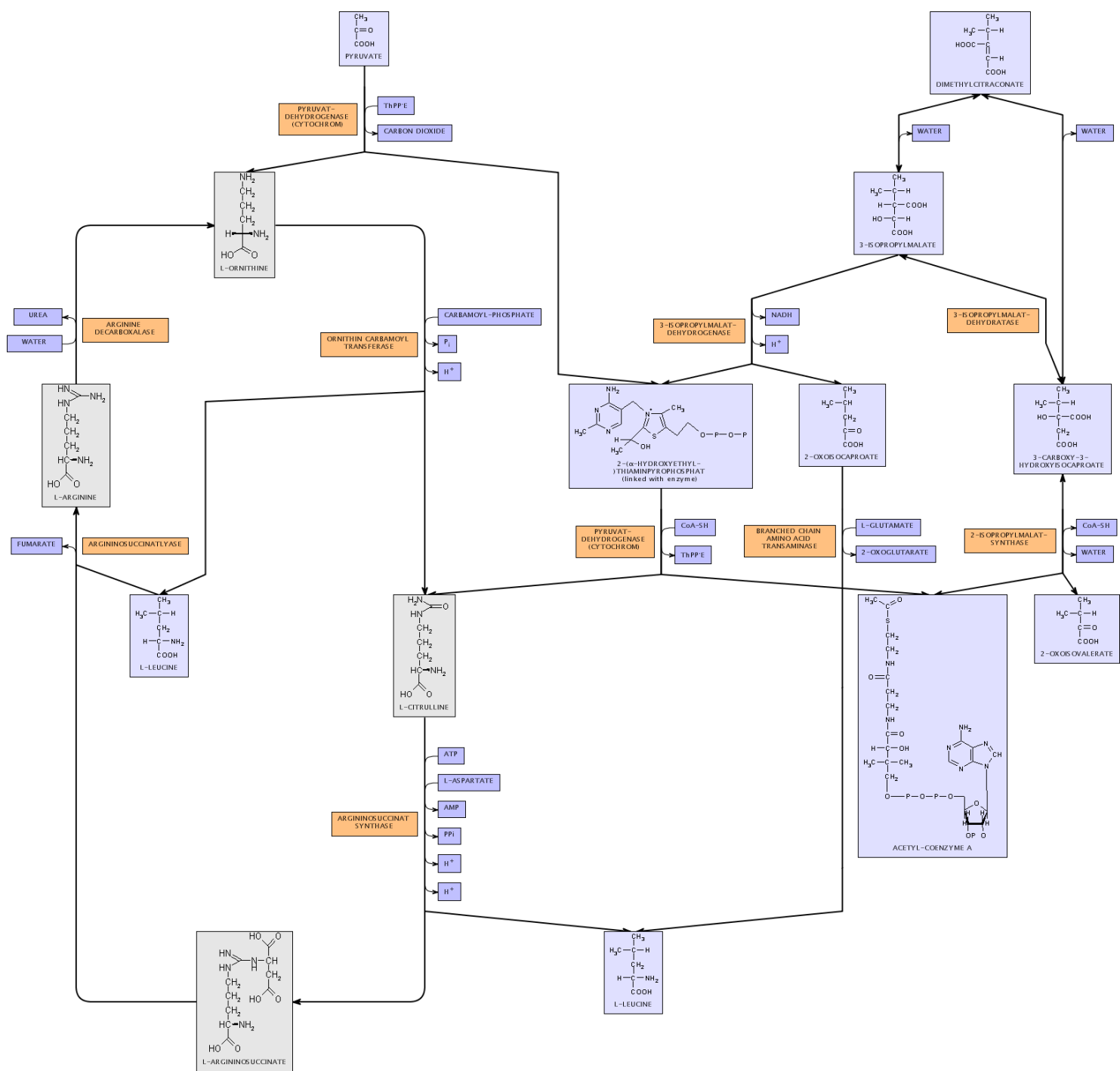



# BioPath Prototype

---

<http://biopath.fmi.uni-passau.de/>

---

Introduction

References

Partners

Guide

Help

Start



---

[page top](#) | [disclaimer](#)

© 2000-2001 <http://biopath.fmi.uni-passau.de>

# System Architecture

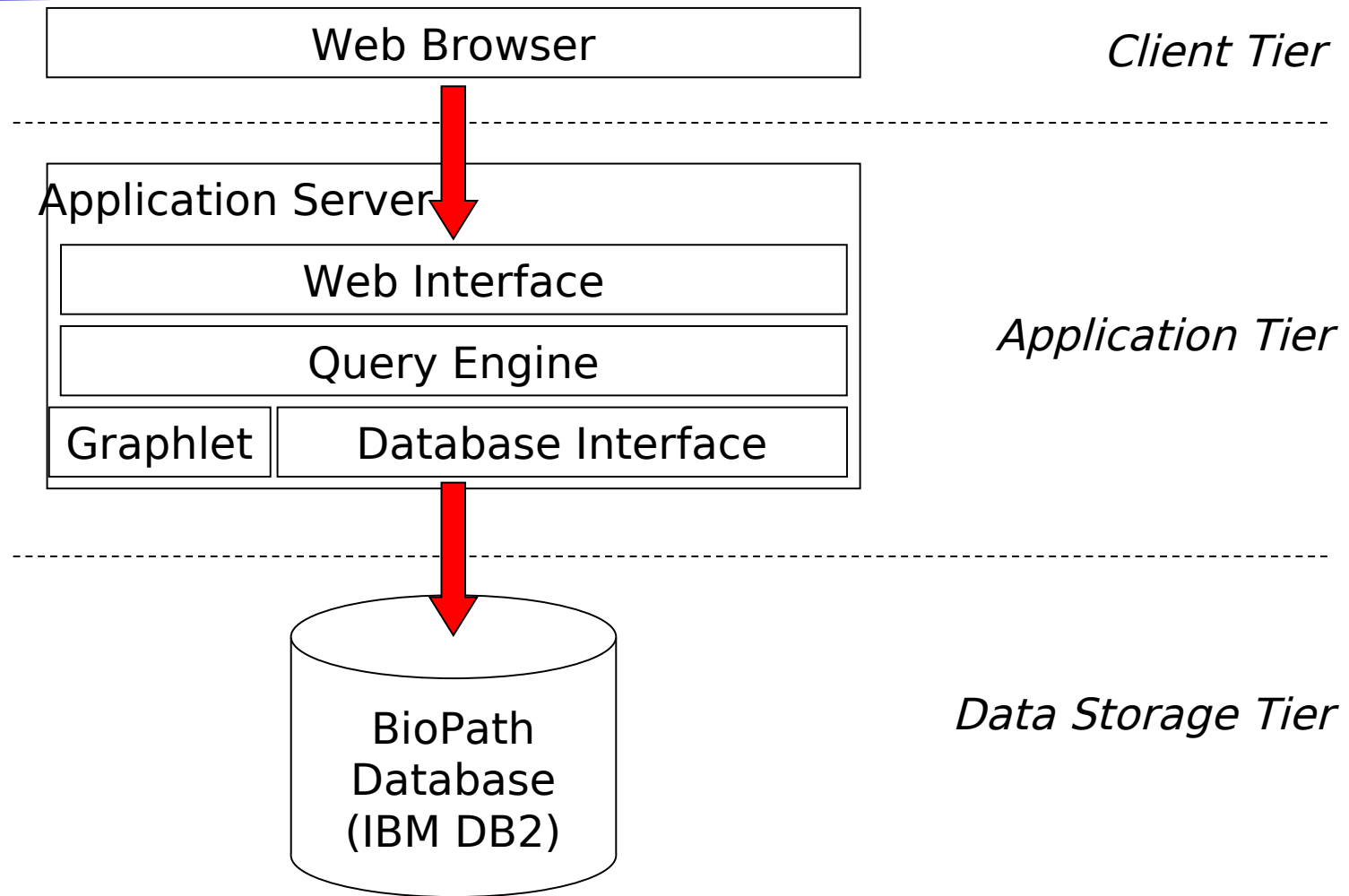

# BioPath Prototype



OVERVIEW

SUBSTANCE

REACTION

REACTION NET

HELP

## Search Reaction Net

From ISOVALERYL-COENZYME A

To ACETYL-COENZYME A

Pathways  Search in one pathway only  
 Search across pathway borders

Search depth 10

Search Reaction Net

[page top](#) | [disclaimer](#)

© 2000 <http://biopath.fmi.uni-passau.de>

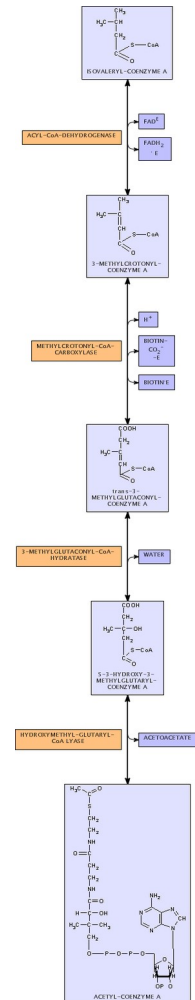





# BioPath - Substances

Names	L-VALINE [English] L-VALIN [Deutsch]
Structural Formula	$\begin{array}{c} \text{CH}_3 \\   \\ \text{H}_3\text{C}-\text{C}-\text{H} \\   \\ \text{H}-\text{C}-\text{NH}_2 \\   \\ \text{COOH} \end{array}$
Empirical Formula	$\text{C}_5\text{H}_{11}\text{NO}_2$
Weight	117.147
Total Charge	0
Reactions	<a href="#">Biosynthesis of L-VALINE</a> <a href="#">Degradation of L-VALINE</a> <a href="#">2-OXOISOVALERATE ---&gt; L-VALINE</a> <a href="#">{L-VALINE, L-VALYL-tRNA}</a>

# BioPath - Reactions

Names Biosynthese von L-VALIN [Deutsch]  
Biosynthesis of L-VALINE [English]

Parents [Branched chain amino acids](#)

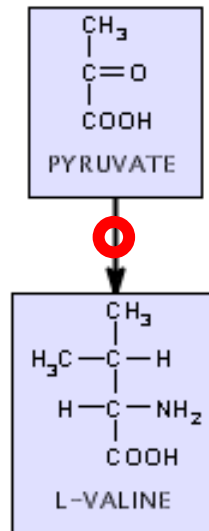

Navigation

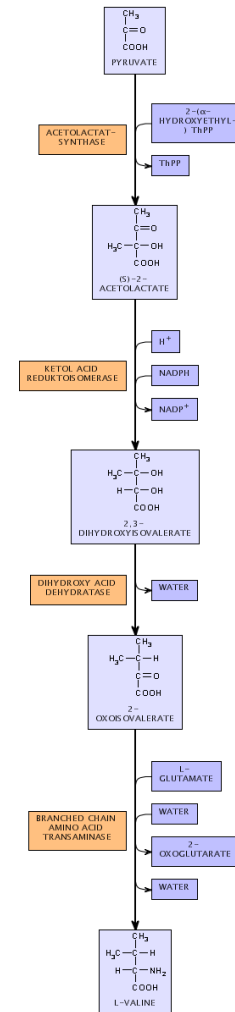

# BioPath - Reactions

Names Biosynthese von L-VALIN [Deutsch]  
 Biosynthesis of L-VALINE [English]

Parents [Branched chain amino acids](#)

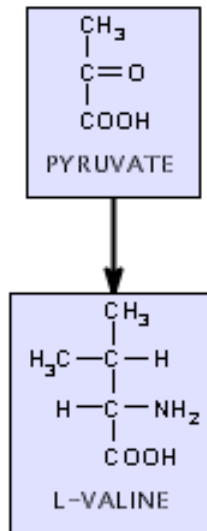

Navigation

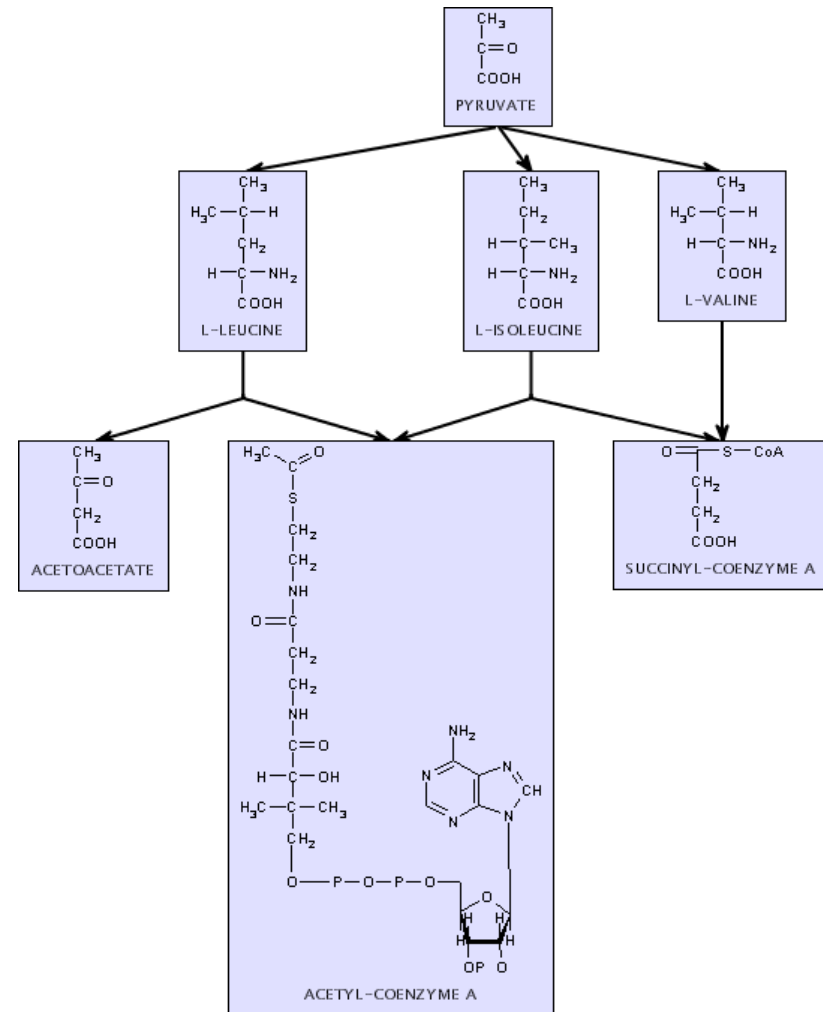

# Perspective

- Signal pathways
- Static visualization example (TRANSPATH)

